

**Andrzej SIOMA, Jarosław SOCHA**

## **AUTOMATION OF ANNUAL TREE INCREMENT MEASUREMENT USING VISION SYSTEM**

*The objective of the study was the development of an automatic measurement method for tree ring increments using a vision system combined with an XYZ scanner. The elaborated method allows for the measurement of increments on cross-section a tree discs or on increment bores. The solution utilizes the XYZ scanner equipped with a vision system, enabling increment measurement during sample scanning. The vision system collects and analyses images of a wood sample. The splicing of partial images enables the construction of a full image of rings, visible on the entire sample surface. Image construction of the studied sample based on a set of magnified partial pictures enables the attainment of very high resolutions, which in top end optical systems, greatly surpasses the resolutions obtained using traditional scanners. The system works automatically and the algorithm of the increment measurement is based on the image analysis of the sample area and is realized in the acquisition time of partial pictures by the vision system. Configuration of the measurement system enables selection of the field of view and measuring resolution. The maximum obtained in the presented system is 0.001 mm.*

**Keywords:** dendrochronology, radial increment, tree-ring measurement, vision system, image analysis

### **Introduction**

One of the most serious challenges of the 21<sup>st</sup> century is climate change and global warming caused by increasing concentrations of carbon dioxide in the atmosphere. Therefore, increasing interest in and the importance of studies concerning biomass and carbon sink by forest ecosystems has been observed [Ochał et al. 2013; Botkin et al. 2014; Zasada et al. 2014]. One of the most important tree characteristics measured during such studies is tree height, the diameter or tree volume increment, which could be obtained by the analysis of tree rings width at various tree heights [Vaganov et al. 2006; Socha and Orzeł 2011]. Tree ring measurement becomes increasingly important in studies concerning the effect of forest management and environmental factors on forest

---

Andrzej SIOMA ([sioma@agh.edu.pl](mailto:sioma@agh.edu.pl)) Department of Process Control, Faculty of Mechanical Engineering and Robotics, AGH University of Science and Technology, Krakow, Poland;  
Jarosław SOCHA ✉ ([rlsocha@cyf-kr.edu.pl](mailto:rlsocha@cyf-kr.edu.pl)) Department of Biometry and Forest Productivity, Faculty of Forestry, University of Agriculture in Krakow, Krakow, Poland

ecosystems [Socha 2012, Seidl et al. 2013]. The difference in diameter increments resulting from the intensity of silvicultural treatments may result in different values of merchantable timber of the forest stands [Bembenek et al. 2014]. Today, however, specialists from other fields also recognize and are investigating the problems of dendrochronology. Tree-ring research has acquired a permanent role in the various sciences of archeology, history, geology, ecology, and climatology [Schweingruber 1993].

The development of computers, X-ray and optic systems have accelerated the evolution of wood surface and tree ring width measurement methodology [Vila-Lameiro and Diaz-Maroto 2007]. Thetford et al. [1991] designed a system that digitizes sample images on an X-ray negative. The developed system required a microtome to take samples from a specimen core. Small ring widths (0.06 mm) were then measurable with a video camera and microscope. The use of X-ray, and HF-densitometry, however, which are primarily dedicated to measurements within annual tree ring density suffer from relatively high equipment costs, time-consuming preparation and measuring procedures [Schweingruber 1990; Schinker et al. 2003]. Digital image methods, reducing subjectivity in the assessment of ring width are examples of solutions used most frequently nowadays [Guay et al. 1992; Simpson and Denne 1997; Bucur 2003; Vila-Lameiro 2003]. These solutions are based on computer software for the analysis of digital images of wood samples to obtain information concerning the number and width of tree rings. This information is necessary to determine the age and diameter, volume or biomass increment of individual trees or stands [Courbet 1999; Vila-Lameiro and Diaz-Maroto 2007].

Measurements taken with the use of digital images require the scanning resolution to be set correctly as well as correct sample preparation. Samples should be ground and cleaned prior to measurement. To increase the measurement resolution and contrast between the rings, increased scanning resolution, (for example up to 2,400 dpi) is used, but it results in an increase of the file sizes, in which the digital picture of samples is saved. An increase in the contrast between the rings is also obtained by technological processing with the use of sample impregnation, fast evaporation or chemical etching [Rose 1957; Campbell 1981] or “shadow technique” [DeRose and Gardner 2010]. Pictures with a high resolution can be also obtained using photographic cameras, but then calibration of each camera setting and each increase of picture magnification with the use of a lens is necessary. Furthermore, correct preparation of samples, including sanding and increasing contrast is also necessary. An alternative group of methods, which gives the possibility of tree ring measurement are vision systems, which allow fast acquisition and an analysis of images, using various methods intended to recognize and locate different image characteristics. Most vision systems can be described as 2D systems, due to information available from the image and the method of performing measurements on the image. The most commonly used vision method is the analysis of greyscale or colour [Kim

and Koivo 1994; Hu et al. 2004; Sandak and Tanaka 2005, Fournier et al. 2010, Jakubowski 2014]. Also used are solutions involving the analysis of tomographic or thermographic images [Meinlschmidt 2005; Wei et al. 2009]. Three dimensional (3-D) vision systems may have an especially promising future [Olszyna et al. 2013, 2014; Romaszko et al 2015; Sioma 2015]. One of the advantages of the 3-D system is that it allows many more measurements and tests to be performed, particularly in the scope of spatial measurements, supplementing and expanding the applied inspection methods.

The objective of the presented study was the elaboration of a new, fully automatic vision system, enabling identification of boundaries and measurement of the width of annual rings on wood samples obtained in the form of bores made with increment bore or disks cut out from the trunk of a cut down tree. Realization of the established aim, required the elaboration of acquisition method and analysis of the images of samples with the vision system combined with the sample positioning system. For the building of a three dimensional representation of ring arrangement, monochrome image was used. The elaborated method includes 3 sets of algorithms, which are used to: 1 – image preparation for the measurements, 2 – determination of ring boundaries and 3 – measurement realization. The study discusses the obtained results and presents the elaborated method compared to measurement methods, which are currently most commonly used for the measurement of the annual tree rings in practice.

## **Material and methods**

The elaborated measurement system consists of the mechanical system, ensuring the realization of sample movement and the vision system with software realizing the image analysis (fig. 1). Three numerically controlled axes were installed in the mechanical system. The measurement table onto which the tested sample is mounted, enables its movement in the XY axis of the stand. The axes of the measurement table are driven by stepping motors, and controlled by the PLC driver managing the operation of the stand. The drive axis Z is responsible for setting the camera height to the surface of the measurement table and the tested sample. The regulation of the camera placement to the measurement table allows control of the FOV (Field of View) on the tested sample. The vision system IVP with 1/3" CCD sensor with a resolution of  $640 \times 480$  was used in the measurement system. The measurement resolution depends on the distance of the vision system from the sample, establishing the field of view defined on the sample. A measurement lens, allowing sharpness to be obtained within a large range of DOF (Depth of Field) was used in the solution. The elaborated measurement system was tested on samples of Scots pine.

The configuration of the vision system was performed to the requirements established at the stage of project preparation, of the automatized measurement system. The following parameters of the vision system were assumed:

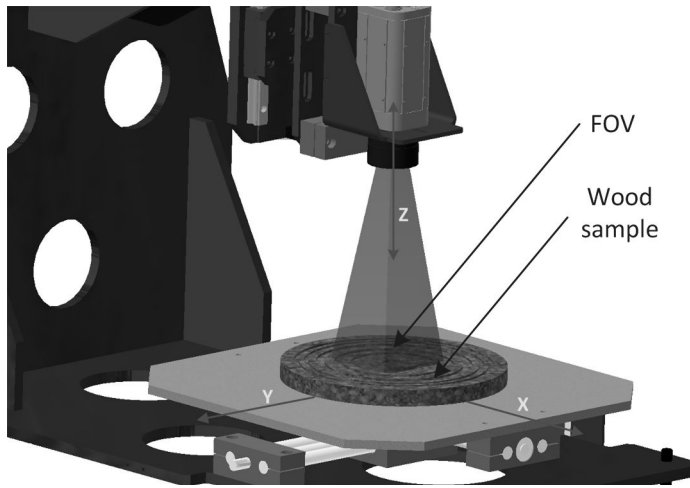

**Fig. 1. View of the test stand**

- the optical system and the sensor of the vision system enable measurement with adjustable resolution of at least 0.05 mm or higher
- the measurement is realized automatically in time under 10 s.
- the measurement results are saved in the database and at the same time, a graphic preview of the results is available to the operator of the test stand.

### **Measurement of increments on bores or increment disks**

In the first stage of the measurement, the grinding sample is mounted on the measurement table and the basing is performed, which enables the adjustment of the pith in the optical axis of the vision system. Then, the field of view of the camera is selected by regulation of the height of the camera positioning to the sample surface. For the selected field of view, the vision system image sharpness check and regulation is performed. Measurements for samples in the form of flat disks, which are flat cross-sections, are realized from the midpoint of a disk, i.e. from the pith. For samples in the form of a "cutout" obtained using test bores in the trunk, the measurements are performed in the mode assumed by the operator, most often from the point of contact between the bark and trunk. The system was tested on Scots pine wood samples.

The analysis of the ring width allows for the use of measurements of a given sample at different field of view sizes. Regulation of the field of view enables the adjustment of the required measuring resolution and its adjustment to the size of rings visible in a sample. Figure 2a presents an image with the largest size and the lowest measurement resolution at the same time. Figures 2b and 2c present smaller FOV and measurement resolutions obtained on the selected surface area. For each camera setting in the Z axis, calibration of the vision

system should be performed, which enables conversion of the results of measurements carried out in pixels to the results provided in the engineering units. If the measurements are realized at the same resolution on subsequent samples, the preparation procedure of the measurement stand is realized only for the first sample.

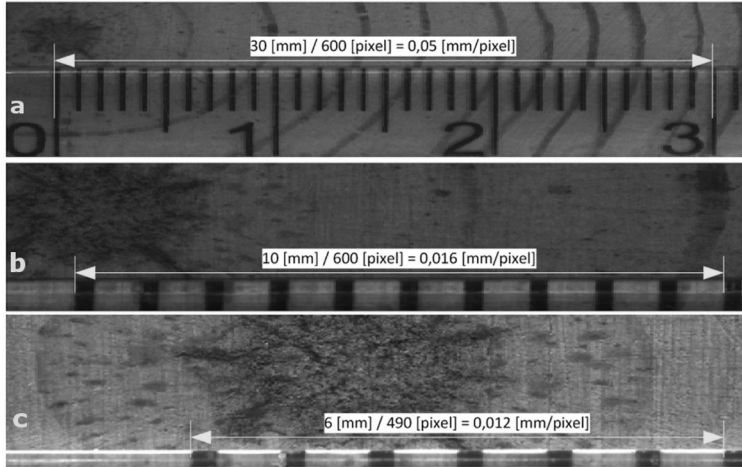

**Fig. 2.** Vision system resolution presented in relation to FOV size: a – FOV = 30 mm with resolution 0.05 mm/pixel, b – FOV = 10 mm with resolution 0.016 mm/pixel, c – FOV = 6 mm with resolution 0.012 mm/pixel

The image analysis in the vision system begins by performing the preliminary transformations, aiming at the preparation of the wood surface image for measurements. For the image recorded by the vision system, visible in figure 3a, point and morphological transformations were conducted, as the result of which a contrasting image of the pith visible in figure 3b was obtained. Thus, the prepared image is used in the determination of the pith midpoint, which was assumed as the measurement basis for the determination of increments visible in the sample.

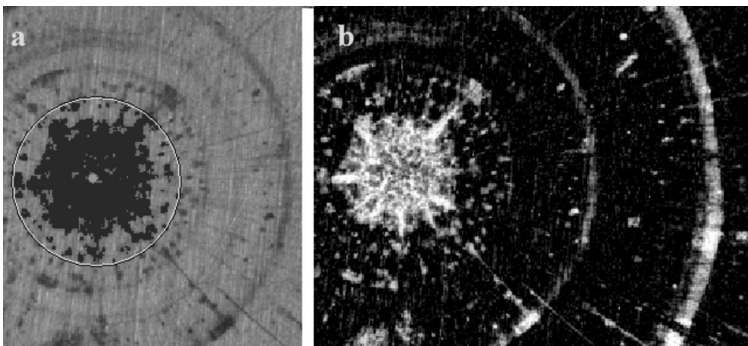

**Fig. 3.** Preliminary image transformations: a – image recorded by vision system, b – image after preprocessing

For the identification of the pith midpoint, the location of the centre of gravity of the area of pith image was used. The pith area was defined using intensity thresholds enabling the determination of pixels belonging the pith, visible in figure 3a. The determination of the centre of gravity is based on the analysis of the location of all pixels creating the area describing the pith (fig. 4). The centre of gravity is determined on the basis of  $x$  and  $y$  coordinates of the location of each pixel creating the area assigned to the object. In the calculations all points of the area or points creating the contour can be included.

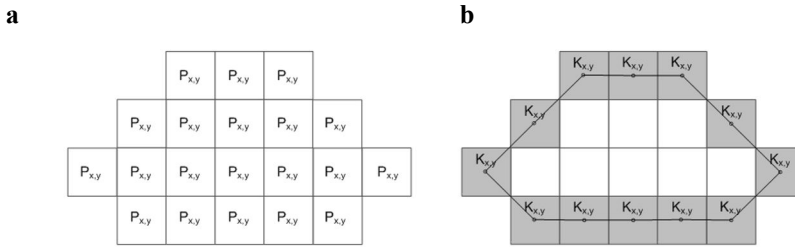

**Fig. 4. Methods of centre of gravity determination for area: a – analysis of all area points, b – analysis of contour points**

Using coordinates of the points creating the area, the centre of gravity location ( $C_X$  and  $C_Y$ ) are determined from equations 1 and 2:

$$C_X = \frac{1}{P} \sum_{1}^P P_X \quad (1)$$

$$C_Y = \frac{1}{P} \sum_{1}^P P_Y \quad (2)$$

where:  $P$  – number of points creating the area,

$P_X$  – coordinate  $X$  of points creating the area in the image,

$P_Y$  – coordinate  $Y$  of points creating the area in the image.

The next stage of the image processing is the determination of the edges describing the ring location on the wood image. Figure 5a presents an image of the real wood surface and 5b an image after point and morphological transformations. After that, transformations aiming at averaging and scaling of the intensity range visible in figure 5c were performed. Preprocessing and determining the edge involves removing wood texture, morphological transformations, image smoothing, intensity scaling and edge detection with the use of derivative intensity. The boundary determination visible in figure 5d was then carried out. Figure 5d presents clear ring boundaries, undisturbed by the presence of information on the texture of the wood surface. Thus, the prepared image was used in the algorithm of increment measurement.

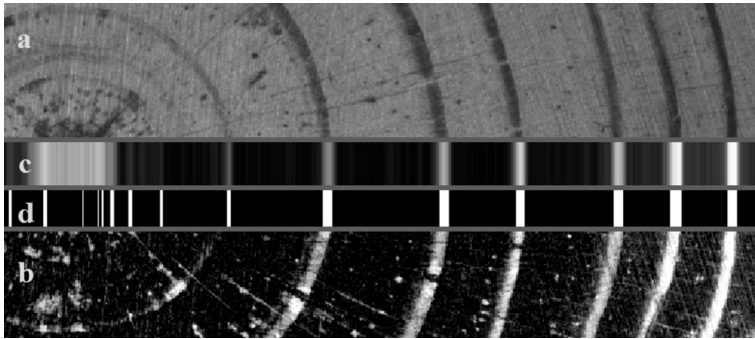

**Fig. 5.** Image of wood surface: a – real, b – point and morphological transformations, c – after filtration smoothing out the intensity scaling, d – ring boundary determination

## Results and discussion

The increment measurement is carried out based on the analysis of the distance between boundaries describing following increments visible in the sample image. For the implementation of the measurements, a coordinate system was defined, which was located in the middle of the pith, determined at the preparation stage of the image for measurements. The identification of the subsequent boundaries is then implemented along the X axis of the coordinate system with the use of image 5d. Using the information on the location of the subsequent boundaries, the distance of each ring from the pith is determined. The first measurement was performed at a resolution of 0.05 mm/pixel, resulting from the assumed FOV. The resolution was obtained at a large FOV, allowing for observation of half of the trunk. Each of the tests was performed 1000 times, for each of the random sample sets using several dozen samples of Scots pine. The paper presents measurements performed for three FOV sizes at three measurement resolutions.

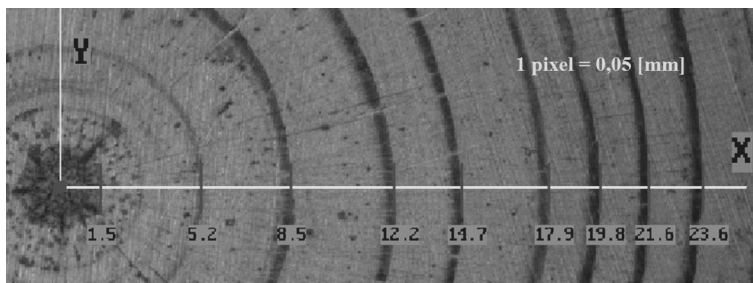

**Fig. 6.** Increment measurements carried out with 0.05 mm resolution

The presented measurement system allows for the automation of the annual ring width measurement. The main advantage of the solution is the possibility of

current adjustments of the measurement resolution to the measured wood samples, which contributes to an increase in the measurement precision. Following the widely known regularities of the course of growth [Assmann 1970] increments layered by trees diminish with age, and thus, the width of rings found on the outer circumference of a trunk is smaller. Furthermore, in the entire life of a tree, a considerable difference in the width of late wood can be observed. The possibility of using variable resolution levels out the problem, which allows for its adjustment for the properties of the studied samples. The example below presents measurements performed at a resolution of 0.027 mm (fig. 7). In order to present the results, only part of the sample image is visible, for which a local coordinate system was assumed, allowing the presentation of the results visible in figure 6.

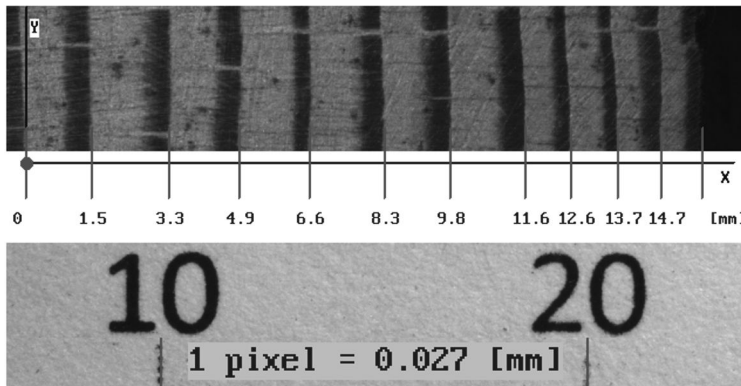

**Fig. 7. Increment measurements carried out with 0.027 mm resolution**

The developed measurement system also allows the automatic identification of shape and size of a pith. The pith area is used for the determination of the midpoint of a wood disk subjected to measurement. A decrease in the FOV and an increase in measurement resolution to 0.012 mm enables a detailed assessment of the pith shape and determination of the parameters describing the pith. Figure eight presents the pith image with a determined circumference describing the pith shape. On the basis of the pith area analysis, the circumference of the pith was determined, expressed in pixels and mean, minimum and maximum radius (fig. 8b). The surface area of the pith image was additionally calculated.

Vision systems were also used in tree ring measurements. Guay et al. [1992] used a line-scan camera to build an image directly from the sanded core or disk specimen. The entire sample image was stored before interactive analysis. At that time, however, the practical limit of the resolution was six rings per millimetre (0.17 mm ring width) for the contrast range of conifer rings. Thanks to the development of the vision systems, which resulted in improved resolutions, it is considered to be very precise at present. Vision systems which are supported by operator's choice concerning resolution and light seem to be the



best solution, and could fulfil the need for an accurate measure of growth increment on many samples of increment cores or stem discs. We developed a nearly automatic method, which could be sufficiently reliable, especially in the case of large samples.

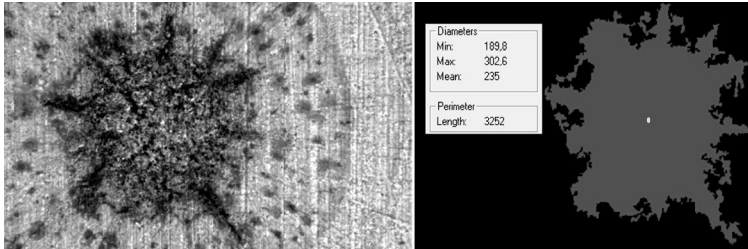

**Fig. 8.** Measurements of pith shape are carried out with a resolution of 0.012 mm

## Conclusions

The realization of measurements on the automatized test stand using the vision system, allows the measurement of increments for one sample to be carried out in approximately ten seconds. Analysis of the image obtained during construction of the surface image is realized in under one second. Implementation of the measurement of samples with large widths of sample rays up to 300 is possible mm. The sample is moved under the vision system, which allows for construction of the image with a high resolution, calculated along the shift axis. It stems from the possibility of automatic splicing of the partial images, carried out for the established field of view. During the sample shift, measurement is carried out with the use of the vision system and information collected in the control system from encoders controlling the current sample location.

Selection of the surface area observed by the vision system and the possibility to control the measurement resolution enables adjustment of the image parameters, i.e. resolution and field of view for the sample size. At the same time, it is possible to splice images, enabling a decrease in the field of view and an increase in the measurement resolution, which allows for the observation of wood surface characteristics which are not visible in the image produced with a lower resolution. The resulting image, created from spliced images with high resolution is characterized by a wide field of view and at the same time high resolution. Measurements can be disrupted by the presence of knots, cracks and other damage. The sample containing the disturbances should be measured several times and algorithm removing damage edges must be used.

The observation and implementation of measurements of pith, and increments with resolution enabling evaluation of pith shape as well as the shape of increment boundary shape are also possible. For such measurements, a small

field of view is selected, enabling a resolution of 0.012 mm or higher to be obtained, depending on the used lens and sensor of the vision system.

The presented solution of this measurement system enables the image construction of a wood sample with selected measurement resolutions. The resolution is selected by the adjustment of the field of view of the vision system. The advantage of the system consists of the ability to perform measurements for the same sample with different resolutions, enabling the evaluation of other surface properties on each of the obtained images. It is possible to measure samples in the form of increment disks, as well as samples obtained using bores. The total measurement time is approximately ten seconds for a sample of any type. The device enables simultaneous measurement of several samples obtained in the bore technology, which increases the efficiency of the measurement work. This version of the measurement system was elaborated on Scots pine species. The system, however, can be easily adapted to other coniferous and ring porous species.

## References

- Assmann E.** [1970]: The Principles of Forest Yield Study. Pergamon Press, Oxford, New York
- Bembek M., Karaszewski Z., Kondracki K., Lacka A., Mederski P.S., Skorupski M., Węgiel A.** [2014]: Value of merchantable timber in Scots pine stands of different densities. *Drewno* 57 [192]: 134–142. DOI:10.12841/wood.1644-3985.S14.09
- Botkin D.B., Ngugi M.R., Doley D.** [2014]: Estimates and forecasts of forest biomass and carbon sequestration in North America and Australia: a forty-five year quest. *Drewno*: 57 [192]: 7-28. DOI:10.12841/wood.1644-3985.S05.01
- Bucur V.** [2003]: Techniques for high resolution imaging of wood structure: a review. *Measurement Science and Technology* 14 [12]: 91-98
- Campbell R.B.** [1981]: Field and laboratory methods for age determination of quaking aspen. USDA Forest Service, Research Note INT-314
- Courbet F.** [1999]: A three-segmented model for the vertical distribution of annual ring area. Application to *Cedrus atlantica* (Manetti). *Forest Ecology and Management* 119: 177-194
- DeRose J.R., Gardner R.S.** [2010]: Technique to Improve Visualization of Elusive Tree-Ring Boundaries in Aspen (*Populus tremuloides*). *Tree-Ring Research* 66 [1]: 75-78
- Fournier M., Dischler J.M., Bechmann D.** [2010]: Image processing algorithm for automated detection of annual ring orientation on wood shingles cross section. *IEEE Symposium on Computer Graphics and Image Processing, Rio de Janeiro, Brazil*: 72-79
- Guay R., Gagnon R., Morin H.** [1992]: A new automatic and interactive tree-ring measurement system based on a line scan camera. *Forestry Chronicle* 68 [1]: 138-141
- Hu Ch., Tanaka C., Ohtani T.** [2004]: Locating and identifying sound knots and dead knots on sugi by the rule based color vision system. *Journal of Wood Science* 50: 115-122
- Jakubowski M.** [2014]: Comparison of algorithms for the automatic determination of the latewood area in wood samples of Scots pine (*Pinus sylvestris* L.) using software ImageJ. *For. Lett.* 107: 16-23.
- Kim C.W., Koivo A.J.** [1994]: Hierarchical classification of surface defects on dusty wood boards. *Pattern Recognition Letters* 15: 713-721

- Meinlschmidt P.** [2005]: Thermographic detection of defects in wood and wood-based materials, 14th International Symposium of Nondestructive Testing of Wood, Hannover, Germany
- Ochal W., Grabczyński S., Orzel S., Wertz B., Socha J.** [2013]: Alokacja nadziemnej biomasy u sosen zajmujących różne pozycje biosocjalne w drzewostanie (Above ground biomass allocation in Scots pines of different bio-social positions in the stand). *Sylvan* 157 [10]: 737-746
- Olszyna G., Sioma A., Tytko A.** [2013]: Assessment of the condition of hoisting ropes by measuring their geometric parameters in a three-dimensional image of their surface. *Archives of Mining Sciences* 58: 643-654
- Olszyna G., Sioma A., Tytko A.** [2014]: Laser measurement system for the diagnostics of mine hoist components. *Archives of Mining Sciences* 59: 337-346
- Romaszko M., Sapinski B., Sioma A.,** [2015]: Forest vibrations analysis of a cantilever beam using the vision method. *Journal of Theoretical and Applied Mechanics* 53: 243-254
- Rose A.H.** [1957]: A technique for differentiating annual rings in increment cores from diffuse porous woods. *Forestry Chronicle* 33: 139-140
- Sandak J., Tanaka C.** [2005]: Evaluation of surface smoothness using a light-sectioning shadow scanner. *Journal of Wood Science* 51: 270-273
- Schinker M.G., Hansen N., Spiecker H.** [2003]: High-frequency densitometry – a new method for the rapid evaluation of wood density variations. *IAWA Journal* 24 [3]: 231-239
- Schweingruber F. H.** [1990]: Radiodensitometry. In: E.R. Cook, A. Kairiukstis (eds.). *Methods of dendrochronology*. Kluwer, Dordrecht
- Schweingruber F. H.** [1993]: *Trees and Wood in Dendrochronology*. Springer-Verlag, Berlin Heidelberg New York, London Paris Tokyo, HongKong, Barcelona, Budapest
- Seidl R, Eastaugh C.S., Kramer K., Maroschek M., Reyer C., Socha J., Vacchiano G., Zlatanov T., Hasenauer H.** [2013]: Scaling issues in forest ecosystem management and how to address them with models. *European Journal of Forest Research* 132: 653-666 DOI: 10.1007/s10342-013-0725-y
- Simpson H.L., Denne M.P.** [1997]: Variation of ring width and specific gravity within trees from unthinned Sitka spruce spacing trial in Clocaenog, North Wales. *Forestry* 70 [1]: 31-45
- Sioma A.** [2015]: The estimation of resolution in 3D range image system. In *Proceedings of the 2013 14th International Carpathian Control Conference (ICCC)*. Eds. I. Petras, I. Podlubny, J. Kacur, et al. Rytro, Poland: 346-349
- Socha J.** [2012]: Long-term effect of wetland drainage on the productivity of Scots pine stands in Poland. *Forest Ecology and Management*. 274: 172-180
- Socha J., Orzel S.** [2011]: Dynamiczne krzywe bonitacyjne dla drzewostanów sosnowych Puszczy Niepołomickiej (Dynamic site index curves for Scots pine stands in Niepołomice Primeval Forest). *Sylvan* 155 [5]: 301-312
- Thetford R.D., Darrigo R.D., Jacoby G.C.** [1991]: An image-analysis system for determining densitometric and ring-width time-series. *Canadian Journal of Forest Research* 21 [10]: 1544-1549
- Vaganov E.A., Hughes M.K., Shashkin A.V.** [2006]: *Growth dynamics of conifer tree rings. Image of past and future environments*. Springer-Verlag Berlin Heidelberg.
- Vila-Lameiro P.** [2003]: *Estudio epidométrico y xilológico de las masas de Quercus petraea (Mattuschka) Liebl. en el noroeste de la Península Ibérica*. Doctoral Thesis. Cd-Rom. ISBN: 84-9750-304-X. Santia

- Vila-Lameiro P. Diaz-Maroto I.J.** [2007]: Use of digital images in computer assisted dendrochronological analysis of deciduous hardwoods. *Wood research* 52 [3]: 15-32
- Wei Q., Chui Y.H., Leblon B., Zhang S.Y.** [2009]: Identification of selected internal wood characteristics in computed tomography images of black spruce: a comparison study. *Journal of Wood Science* 55: 175-180
- Zasada M., Bijak S., Bronisz K., Bronisz A.** [2014]: Biomass dynamics in young silver birch stands on post-agricultural lands in Central Poland. *Drewno* 57 [192]: 29-39  
DOI:10.12841/wood.1644-3985.S07.02

### **Acknowledgements**

This paper was written as part of statutory research carried out at the AGH University of Science and Technology in Department of Process Control in cooperation with the University of Agriculture in Krakow, Department of Biometry and Forest Productivity (DS-3418/ZBiPL/16). The cooperation of both Departments aims to develop automatized, efficient measurement systems, enabling the measurement of large quantities of increment samples obtained within the framework of the study on the growth and productivity of the forest.